

LambdaFLEX™ iTLA

TL5000VLJ Integrable Tunable Laser Assembly with variable output power

Features:

- Full L-Band tunable source (1568.7-1607.5nm) based on OIF iTLA footprint
- High power +10dBm EOL
- Variable power range of 6dB
- High speed electronic tuning control (<10ms channel to channel)
- Electronic shutter for dark tuning
- Low power dissipation, 3.8W typical
- Narrow line-width, 5MHz maximum
- Excellent SMSR >40dB
- Low RIN
- Wavelength stabilized for 50GHz or 100GHz ITU-T channel spacing
- Optical power monitor
- FM Dither / Trace tone capability
- Case operating temperature range -5°C to +75°C
- Simple RS232 interface
- RoHS compliant 
- Telcordia Qualified to GR 468

Applications:

- Long Haul/Ultra Long Haul
- Regional Metro
- Test and Measurement



The Oclaro LambdaFLEX™ iTLA is a high performance continuous wave (CW) tunable laser source for use in the L-band window covering 1568nm to 1607nm. Based on the OIF iTLA standard, the laser and control electronics are pre-mounted on a dedicated circuit board for easy production installation. The iTLA features variable power, shuttered tuning, trace tone and FM dither circuitry. Comprehensive control and system reporting is provided over the RS232 interface.

The iTLA implements the Oclaro DSDBR wideband tunable laser. This laser is a fully monolithic InP chip designed for high volume, low cost manufacturing. With no moving parts, it is a low voltage electronically tuned device enabling rapid wavelength switching with straightforward control electronics. The integrated semiconductor optical amplifier (SOA) provisions the optical power control and also acts as a shutter to allow dark tuning when reverse biased.

Laser chip operation is at a fixed temperature. Wavelength stability is guaranteed by an internal wavelength locker for control to a 50GHz or 100GHz ITU wavelength grid. Front facet output power monitoring is also provided by the wavelength locker for feedback control through the SOA. The device is provided with polarization maintaining fibre for use with an external modulator.

Optical Characteristics

The following parametric limits detailed are for a case temperature range of -5°C to 75°C.

Parameter	Min	Typ	Max	Unit	Conditions
Output Power	+5		+11	dBm	Note [4]
Optical output power tolerance	-0.8		+0.7	dBm	Note [5]
Variation in optical output power over the wavelength range		±0.2	±0.4	dB	Fixed set power value and fixed case temperature
Frequency Range	186.5		191.1	THz	L band, 93 channels, 50GHz spacing
Wavelength Range	1568.77		1607.47	nm	L Band
No of Channels	93				50GHz spacing
SMSR	40	45		dB	
Linewidth		1	5	MHz	Lorentzian
RIN (10MHz-1GHz) (1-10GHz)			-110 -145	dB/Hz	Average RIN
OSNR	50	55		dB	0.1nm optical bandwidth
Polarization extinction ratio	20			dB	
Return Loss		-50	-40	dB	
Back Reflection Tolerance	-8.2			dB	For RIN <-140dB/Hz
Locked frequency accuracy	-1.8		+1.8	GHz	EOL [6]
Shuttered output power		-35	-30	dBm	
Linewidth for Brillouin suppression	250		1000	MHz	
Brillouin frequency selection	10		100	kHz	Note [1]
Trace Tone Frequency	10		500	kHz	Note [1]
Trace Tone Modulation Depth		4	10	%	
Tuning Speed			10	ms	Various scenarios apply [2]
iTLA 'cold-start' initialisation time			60	s	Note [3]

Notes:

- [1] The Oclaro iTLA incorporates a single onboard oscillator which is used to provide either non-linearity suppression or Trace Tone functionality, but cannot provide both functions simultaneously. However the iTLA MFR1 input can be used to enable an external frequency source to be applied enabling both non-linearity suppression and Trace Tone functionality.
- [2] The Oclaro laser is guaranteed to tune within 10ms which is to comply with the OIF "Application A" (SONET/SDH Protection), however, this applies only for tuning between channels, with or without the laser enabled (host sending the change channel command only). Enabling the laser from a disabled state will take longer, as the tuning has to be executed more slowly, in order to comply with the ramped power vs frequency mask specification. In either case, the host must monitor, process and respond appropriately to the status bits of the iTLA out-bound (module to host) response packet, generated in response to each host command.
- [3] Time required from application of Vcc and Vee supplies for the iTLA to reach an operational state. Complies with the OIF MSA module warm up time.
- [4] This is defined as the Start of Life (SOL) power adjustment range, specified at an iTLA case temperature of 25°C.
- [5] Specified over product life, operational temperature range and channel optical power budget.
- [6] Better than specified iTLA OIF MSA V01.1 Applications requirements, section 10.1.2

iTLA Frequency versus Power Mask

The iTLA is guaranteed to comply with the frequency versus power mask shown below. This mask applies during iTLA power enable and disable operations and also during channel changing operations.

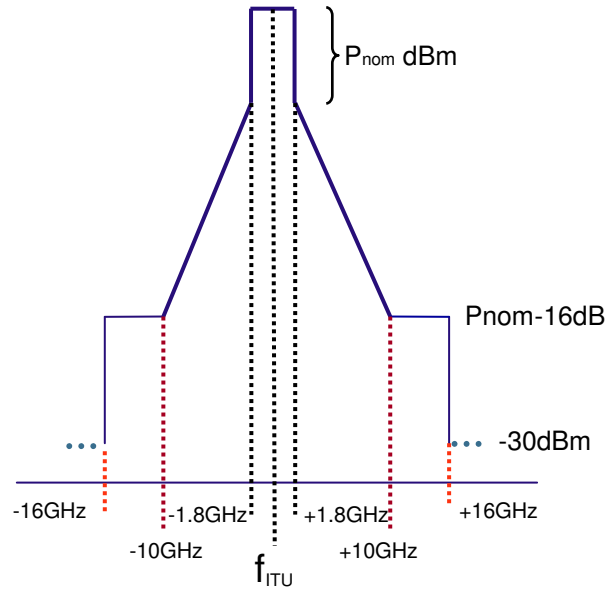

Electrical Characteristics

Parameter	Min	Typ	Max	Unit	Conditions
+3V3 supply voltage	3.15	3.3	3.45	V	
+3V3 supply current		1100	1500	mA	
-5.2V supply voltage	-5.45		-4.94	V	
-5.2V supply current		30	100	mA	For shuttered operation only
Power Dissipation		3.8	5.5	W	
LVTTL Input V_{IN} LOW			0.8	V	
LVTTL Input V_{IN} HIGH	2			V	
LVTTL Output V_{OUT} LOW			0.5	V	
LVTTL Output V_{OUT} HIGH	2.4			V	
Power Supply Noise			1	%rms	100Hz to 20MHz
RS232 Interface	9600		115200	Baud	Default 9600 baud

Environmental Characteristics

Parameter	Min	Typ	Max	Unit	Conditions
Storage Temperature	-40		+85	°C	
Operating Temperature	-5		+75	°C	With suitable heatsink
Operating Humidity	5		85	%RH	
Electrostatic Discharge	500			V	MIL-STD-883, Method 4
Flammability	V0				Fibre coat UL94-HB <1 gm mass

iTLA Block Diagram

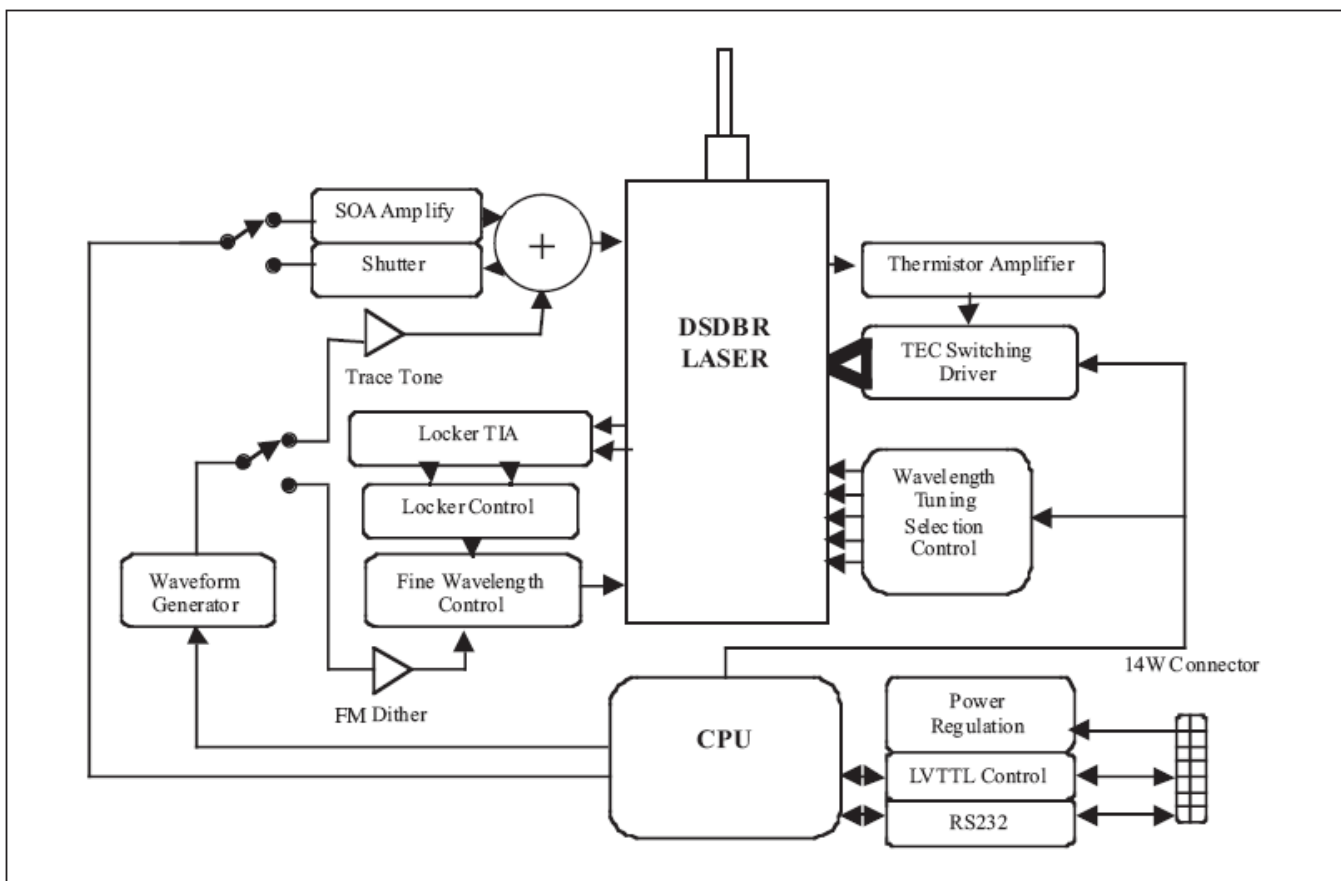

Connector Signal Function

Name	Function	Active	Description
DIS	Disable Laser	LOW	Optical output terminated
SRQ	Service Request	LOW	Service interrupt poll
MS	Module I/O reset	L→H edge	Resets I/O physical interface
TXD	RS232 transmit data		LVTTTL RS232 Tx
RXD	RS232 receive data		LVTTTL RS232 Rx
RST	Reset	LOW	Laser off, module in reset
MFR1	See note below		Manufacturers connection only
OIF	Reserved	LVTTTL input	For future use

Notes:

This pin can be factory configured to provide an external trace tone input. This allows an external sine wave signal to modulate the laser output power (AM). This input can be used simultaneously with the internal non-linearity suppression dither function.

This input will accept a signal amplitude between 0 and 1Vpp and has a -3dB frequency bandwidth of approximately 3KHz to 2MHz.

The transfer function is not controlled so that the user must monitor the resulting AM and adjust the input signal amplitude so as to produce the required modulation depth. This input is internally AC coupled. Absolute maximum input is 3Vpp.

Mechanical Detail (dimensions in mm)

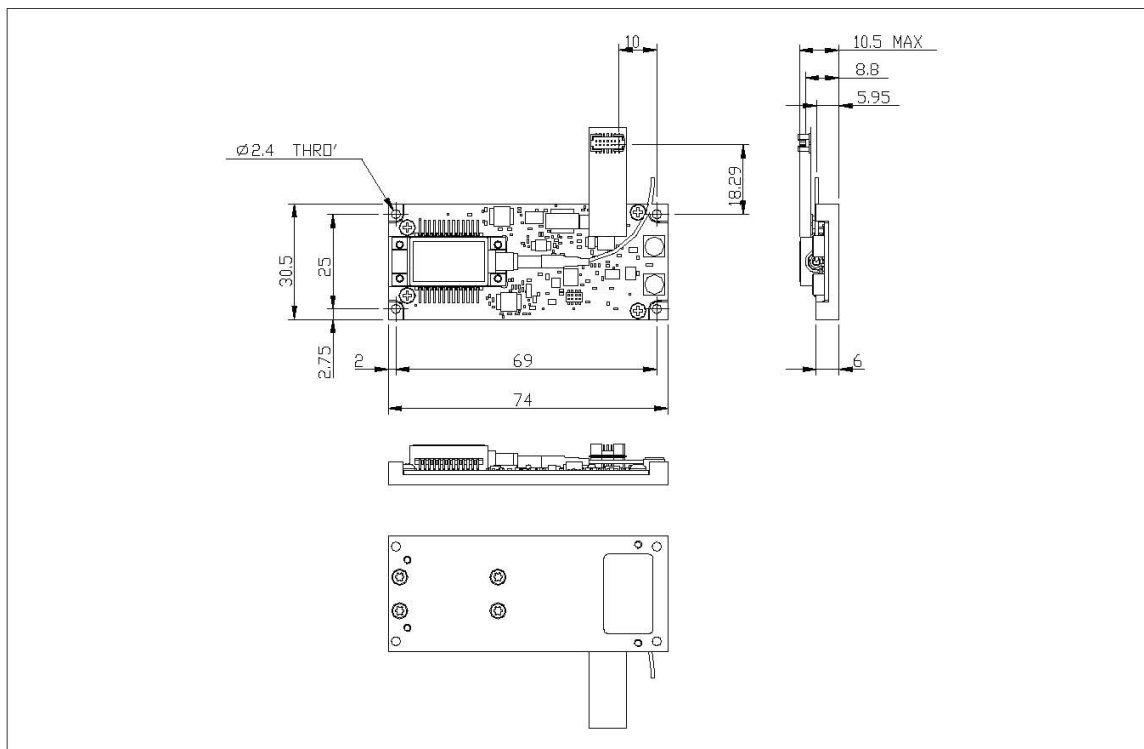

- 14 way Pin Connector designed to mate with Samtec P/N ASP-113466-019 or equivalent.
 - Module attached with 4 X M2 screws, clearance hole in iTLA, threaded in user housing.
- The module should be mounted to a flat heat sink or thermal pathway for correct device operation. The module thermal management should ensure that the case temperature does not exceed 75°C at the worst case end of life dissipation figure of 5.5 Watts.

Physical Connectivity

Pin Out Table

Pin #	Function	Pin #	Function
1	3V3	2	DIS
3	3V3	4	SRQ
5	GND	6	MS
7	GND	8	TXD
9	-5.2V	10	RXD
11	-5.2V	12	RST
13	OIF	14	MFR1

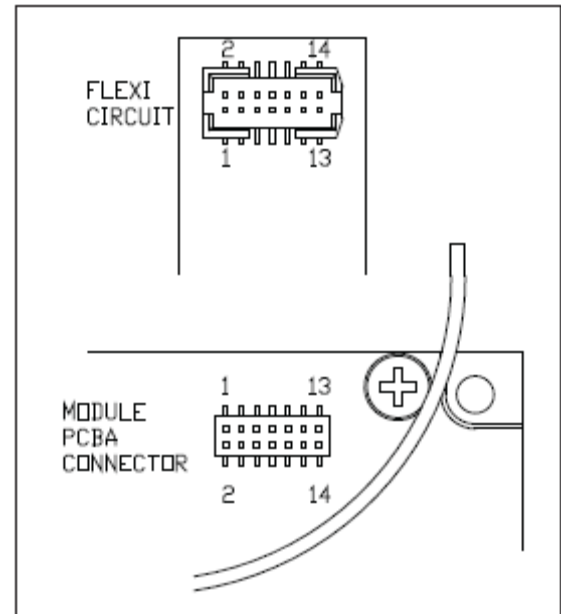

Customer Support and Handling Recommendations

An iTLA evaluation kit is available which provides a hardware platform to test and characterise the Oclaro iTLA. It provides convenient connection for iTLA power supplies, LED power indicators and a selection of module enable/disable and software/hardware reset switches. This kit also includes a convenient GUI software applications interface which enables host/iTLA communications using the OIF MSA recommended packet structure via the RS232 interface, enabling comprehensive control and status interrogation.

Please refer to your local sales representative for iTLA evaluation kit availability.

iTLA product support documents are also available on request. The Oclaro applications document *Handling and Operation Recommendations for the Oclaro Integrable Tunable Laser Assembly (iTLA) D00041-AN*, provides recommendations and advice regarding handling, mounting and operation of the iTLA to enable straightforward integration of the iTLA into a clients' system card.

Optical Fibre

Fibre Length	1400mm +/- 100mm
Fibre coating	900um split loose tube
Fibre Type	PANDA 9/125 polarization maintaining fibre
Minimum Bend Radius	20mm
Connector	FC-UPC

RoHS Compliance



Oclaro is fully committed to environment protection and sustainable development and has set in place a comprehensive program for removing polluting and hazardous substances from all of its products. The relevant evidence of RoHS compliance is held as part of our controlled documentation for each of our compliant products. RoHS compliance parts are available to order, please refer to the ordering information section for further details.

Ordering Information:

TL5000VLJ

FC/UPC connector supplied as standard. This connector is present for testing purposes only. It is expected to be removed by the customer to allow connection splicing.

Evaluation Board Available on request.

Patents

This product is protected by US patent numbers 6,658,035, 6,654,400, 6,687,278, 6,345,135, 7,145,923, 7,394,838, 7,680,374 and other patents and applications pending worldwide.

Contact Information

www.oclaro.com

Important Notice

Performance figures, data and any illustrative material provided in this data sheet are typical and must be specifically confirmed in writing by Oclaro before they become applicable to any particular order or contract. In accordance with the Oclaro policy of continuous improvement specifications may change without notice. The publication of information in this data sheet does not imply freedom from patent or other protective rights of Oclaro or others. Further details are available from any Oclaro sales representative.



Caution - use of controls or adjustments or performance of procedures other than those specified herein may result in hazardous radiation exposure.

D00092-PB Issue 07 February 2011

©Oclaro 2011. Oclaro the Oclaro, Inc. logo, and all other Oclaro, Inc product names and slogans are trademarks or registered trademarks of Oclaro, Inc. in the U.S.A. or other countries. Information in this datasheet is subject to change without notice.